

Whisper Winch Attachment

Part #: 1004488



Parts List		
QTY	PART NUMBER	DESCRIPTION
2	1000513	Winch Mounting Bolt
2	1000536	Set Screw 3/8-16 x .375 SS

STEP 1

Attach the two Winch Mounting Bolts to the Whisper Winch - as shown.

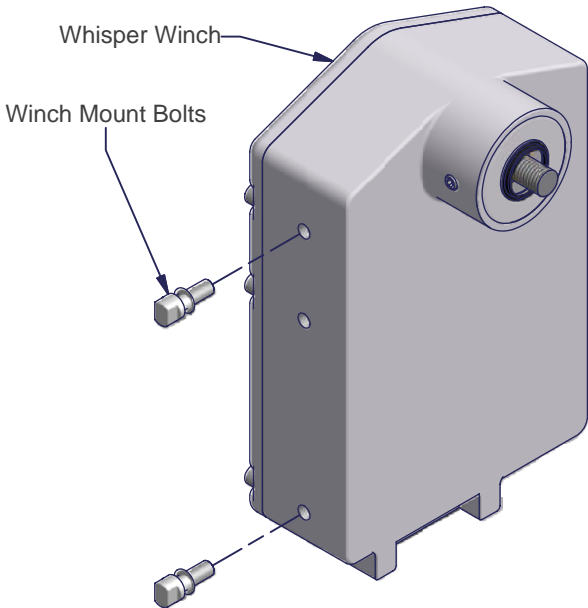

STEP 2

Insert the the Winch Mounting Bolts into the Mounting Slots of Winch Mount - as shown.

Thread two Set Screws 3/8 x 3/8 into the holes at the top of the Winch Mount Clamp and tighten against the Whisper Winch, locking it in place - as shown.

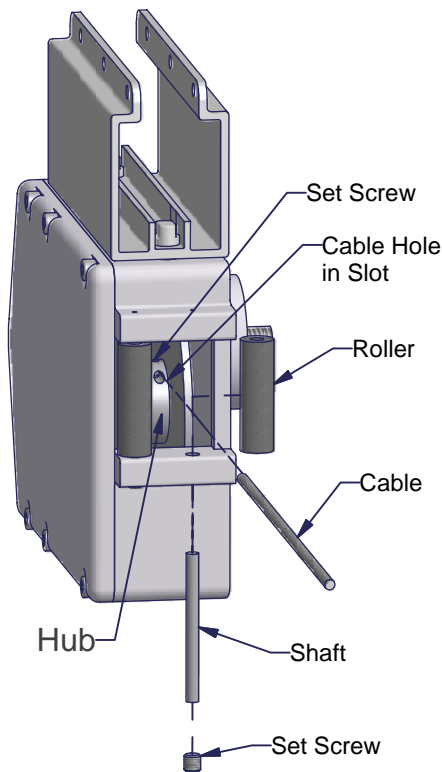
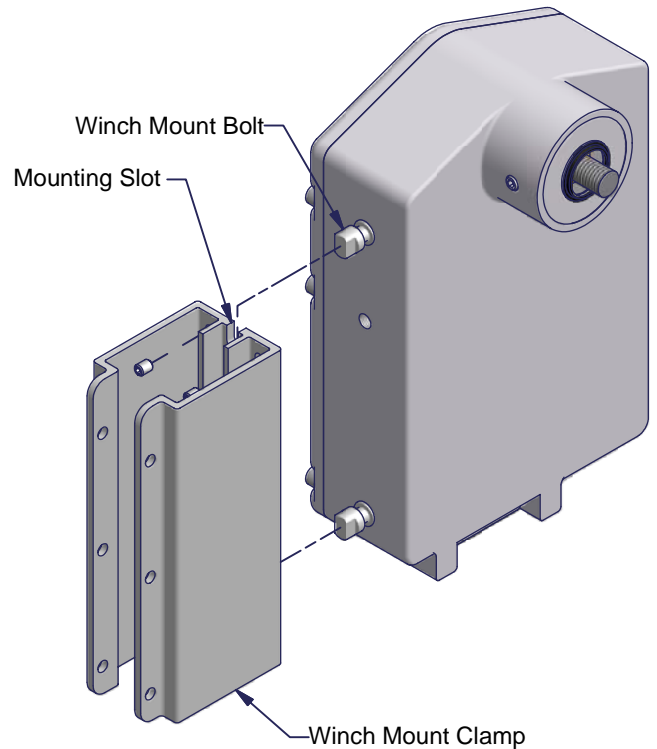

STEP 3

Loosen Set Screw on the side of the Whisper Winch that has the Brake assembly. Remove the Shaft and Roller to access the Hub.

Slide the end of the cable into the Slotted opening on the Hub. Tighten Set Screw using a 5/32" allen wrench to secure the cable to the Hub - as shown.

Replace the Roller, Shaft and Set Screw.

NOTE: Cable must run between Rollers and enter at slotted end of opening through hub as shown. Slide cable fully into hub opening. However do not go so far that the cable sticks out the other side of hole. This would interfere with proper cable wrapping.