

Part # 1006676 - 4' / 1006677 - 8' QC 4' & 8' Ramp Instructions

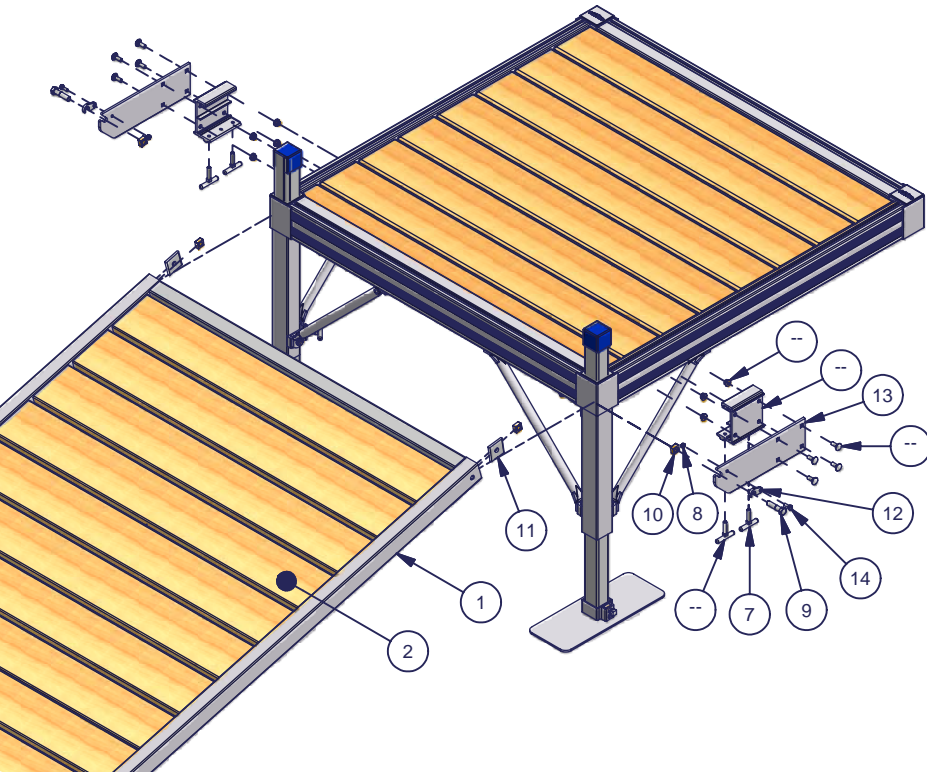
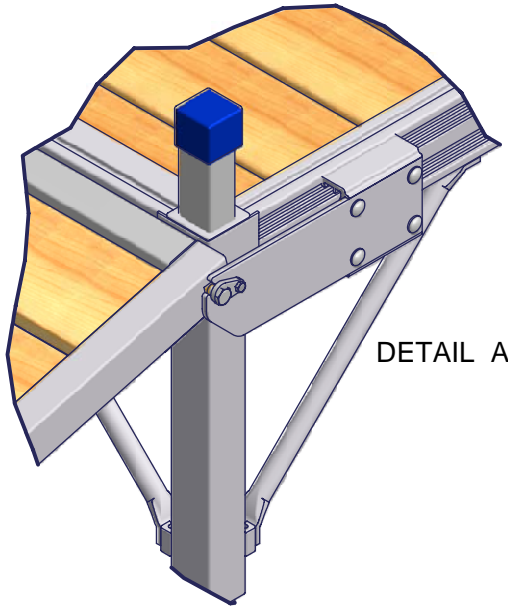
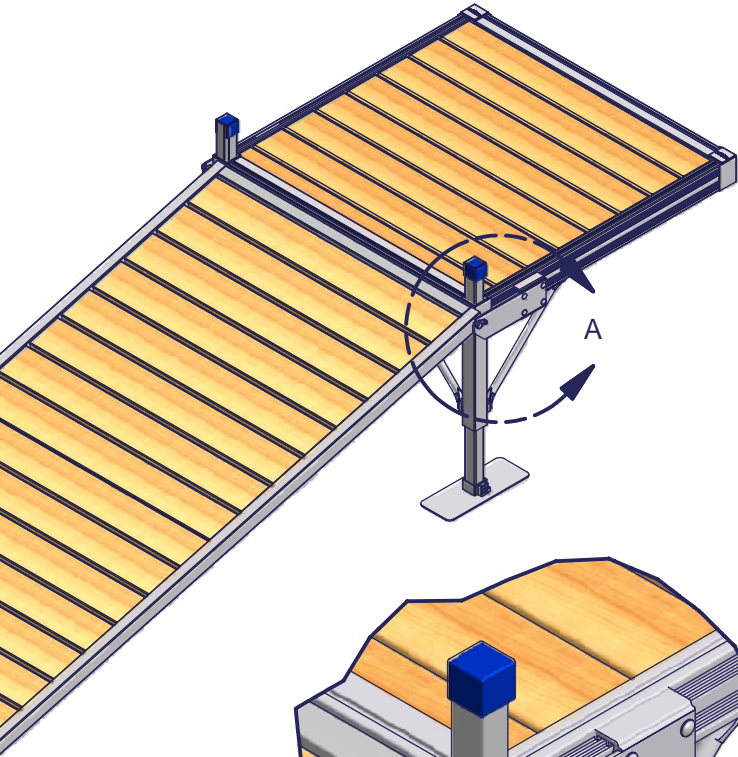

Step 1: Attach each Connection Plate to QC Bracket (Sold Separately)

Note: A second T Handle must be used each QC Bracket (included with Ramp)

Step 3: Secure QC Brackets 6 1/2" away from the end of the dock.

Step 4: Thread one Nut Square 1/2 all the way onto one Bolt Hex 1/2 x 2.0.

Step 5: Insert one Nut Square 1/2 into the tube of the Ramp Frame. Insert Bolt Hex 1/2 x 2.0 through the hole in ramp frame and thread onto the Nut Square 1/2 and securely tighten together.

Note: On the Ramp Frame 4ft x 8ft only a Reinforcement Plate must be insert into the tube.

Step 6: Attach one Clip to each Connection Plate using one Bolt Hex 1/4 x .75 and one Nut Nyloc 1/4.

Note: Do Not fully tighten so Clip can pivot.

Step 7: Set the exposed bolt heads on the ramp into the slots on the Connection Plates and rotate the Clips over the bolt shafts to secure ramp and tighten Clip bolts.

Panels and QC Accessory Brackets sold separate.

Parts List			
ITEM	QTY	PART NUMBER	DESCRIPTION
1	1	1003803	Wdmt Ramp 4Ft X 8Ft QC
		1003837	Wdmt Frame Ramp 4Ft X 4Ft QC
2	2	--	Panels (sold separate)
--	1	1004576	Bolt Bag QC Ramp
7	2	1000876	T Handle
8	2	1001798	Nut Nyloc 1/4
9	2	1002379	Bolt Hex 1/2 x 2.0
10	4	1001793	Nut Square 1/2
11	2	1003254	Reinforcement Plate
12	2	1001092	Clip
13	2	1001123	Connection Plate
14	2	1000557	Bolt Hex 1/4 x .75