

## QC Ramp Connection Kit to 45 Curve Dock Instructions

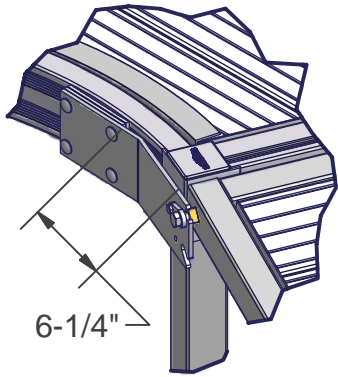

DETAIL B

**Step 1:** Assemble side of ramp that will use the accessory bracket (item 3.13) by following the instructions that are included with the ramp.

**Step 2:** Assemble opposite side of ramp connection by placing one of the accessory connector plates (items 3.3) so it is positioned 6-1/4" back from the end of the dock section (as shown in detail-B). Mark and drill four 7/16" holes for the plate through the dock frame.

**Step 3:** Bolt Connection plate-B (item 3.2) to dock frame using four carriage bolts (item 3.4) two accessory plates (item 3.3) for spacers and four flange nuts (item 3.5).

**Step 4:** Finish assembly of ramp according to ramp instructions.

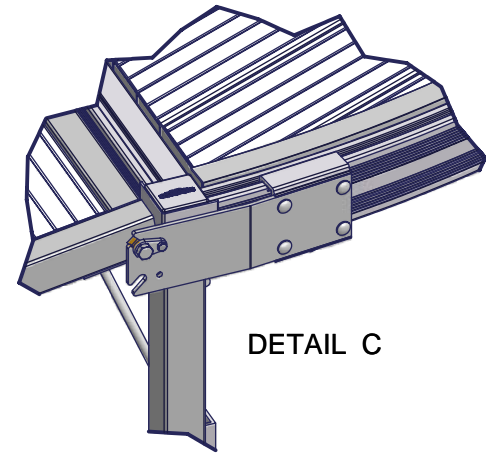

DETAIL C

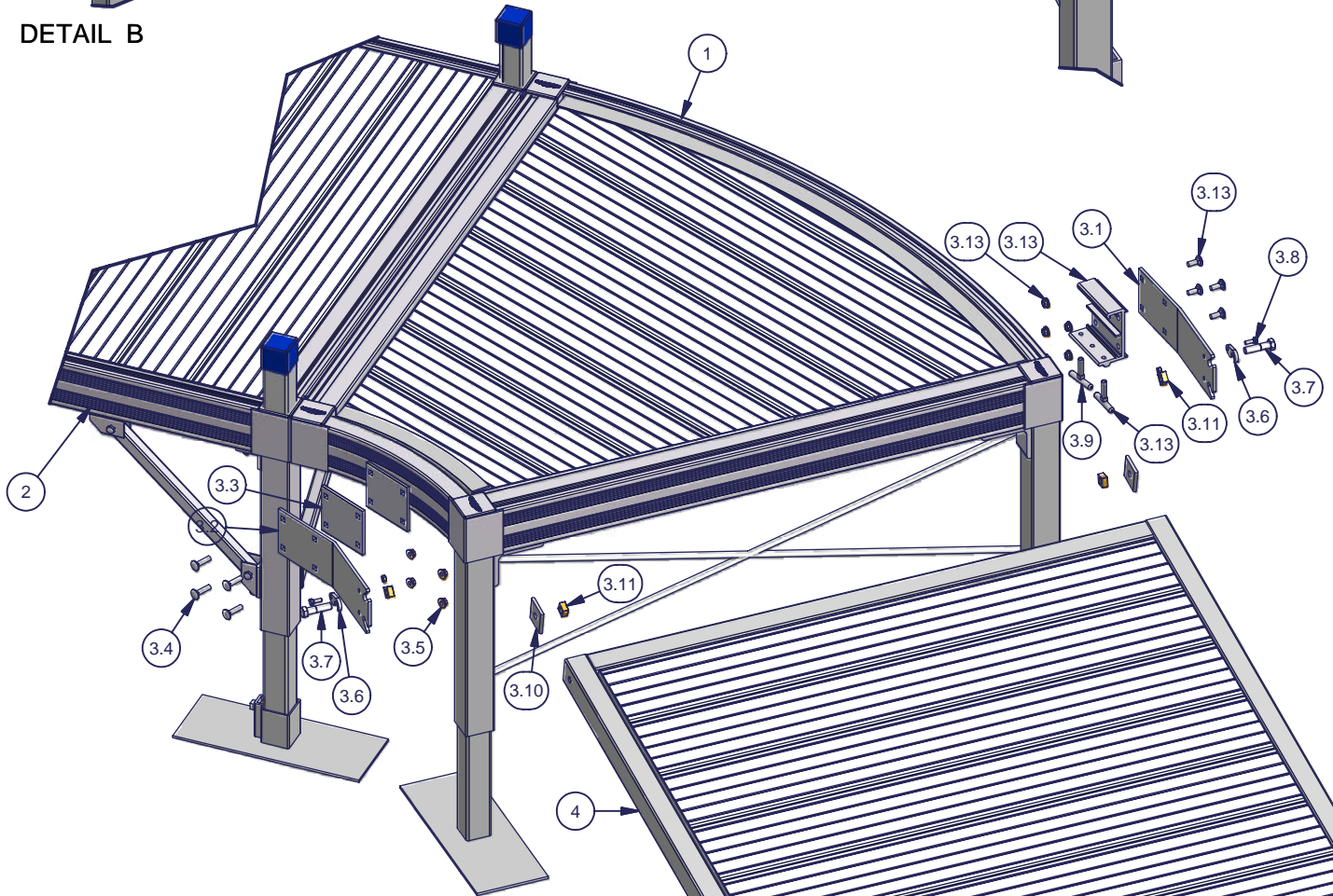

Parts List			
ITEM	QTY	PART NUMBER	DESCRIPTION
1	1	--	RS-4 Curve Dock (sold separately)
2	1	--	RS-4 Dock (sold separately)
3	1	DABBRMP45	QC Ramp Connection Kit to 45 Curve Dock
3.1	1	635016129	QC Ramp Connection plate-A to 45 curve dock
3.2	1	635016130	QC Ramp Connection plate-B to 45 curve dock
3.3	2	005015666	Acc Con Plate 4.5in
3.4	4	CS380150B	BOLT CARR 3/8 - 16 X 1.5 SS
3.5	4	B380FLNUT	3/8" FLANGE NUT BRASS
3.6	2	630016125	QC Ramp Clip (In Ramp Bolt Bag)
3.7	2	MS120200B	BOLT 1/2 - 13 X 2 SS (In Ramp Bolt Bag)
3.8	2	500017391	1/4" x 3/4" Hex Bolt SS
3.9	1	600015660	T Handle 2.5 w/ 3/8 - 16 x 1.5 - Cup Point
3.10	2	035016121	QC Ramp 4' x 8' Reinforcement Plate (In Ramp Bolt Bag)
3.11	4	B120SQNUT	NUT SQUARE 1/2 - 13 BRASS (In Ramp Bolt Bag)
3.12	2	B14LOCNUT	NUT 1/4 - 20 NYLOC BRASS (In Ramp Bolt Bag)
3.13	1	DARS4QCAB	RS-4 QC Accessory Bracket (sold separately)
4	1	DAQC8PARM	QC Ramp 4' x 8' with White Alum Deck (sold separately)