



# Bolt-On Ramp Roller Kit

Part Number: DARAMPRLK

**Step 1:** Position ramp roller bolt-on kit weldment (item 9) on bottom side of ramp (item 1) set in from the side of the ramp about 3". Mark the two holes and drill through ramp tube using a 7/16" drill bit.

**Step 2:** Insert 3/8" carriage bolts (item 8) through previously drilled holes in ramp and through ramp roller bolt-on kit weldment (item 9) and secure with 3/8" washers (item 6) and 3/8" nuts (item 7).

**Step 3:** Attach rollers (item 2) to ramp roller bolt-on kit weldment (item 9) and secure with 1/2" bolt (item 5), 1/2" washer (item 3) and 1/2" nut (item 4).

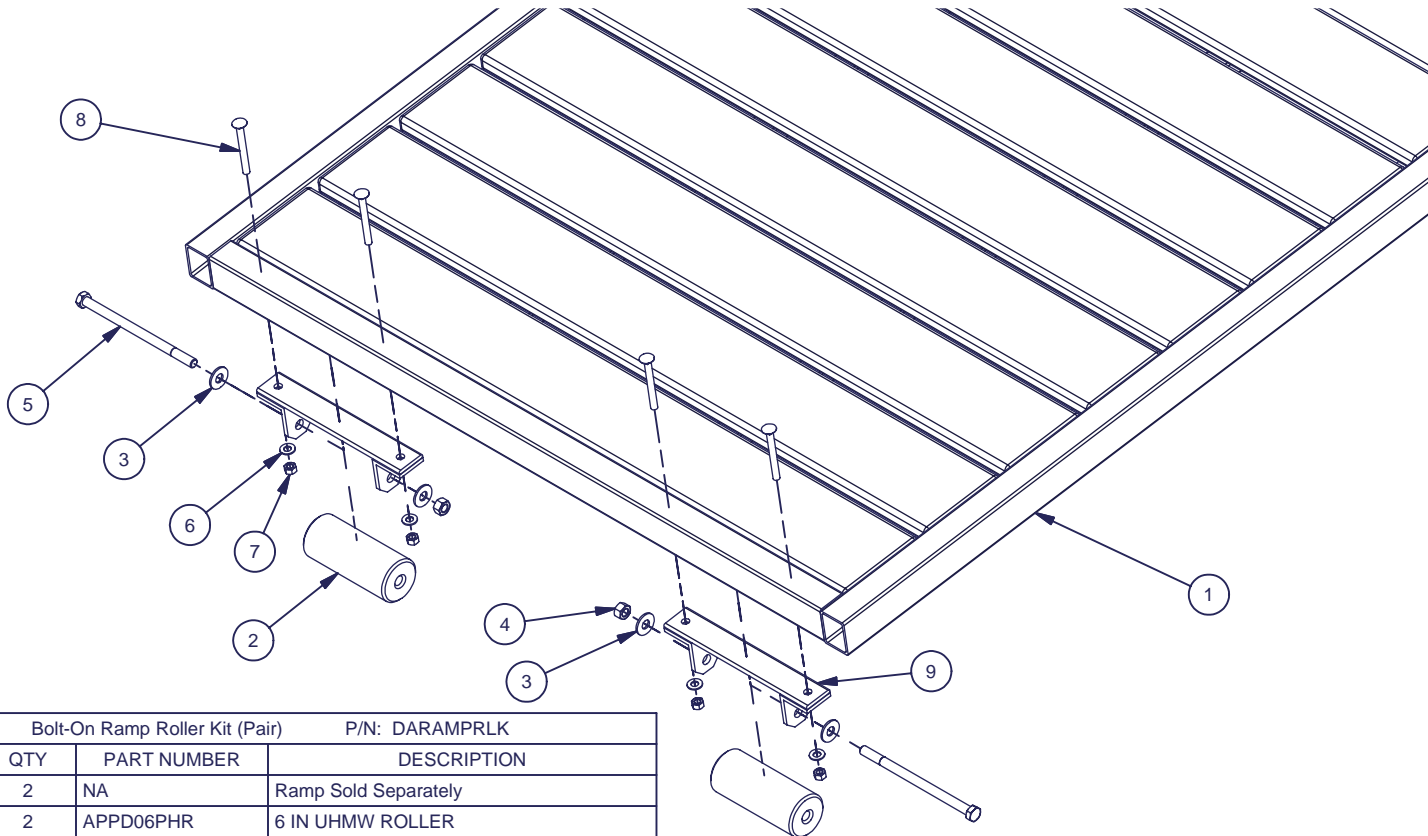
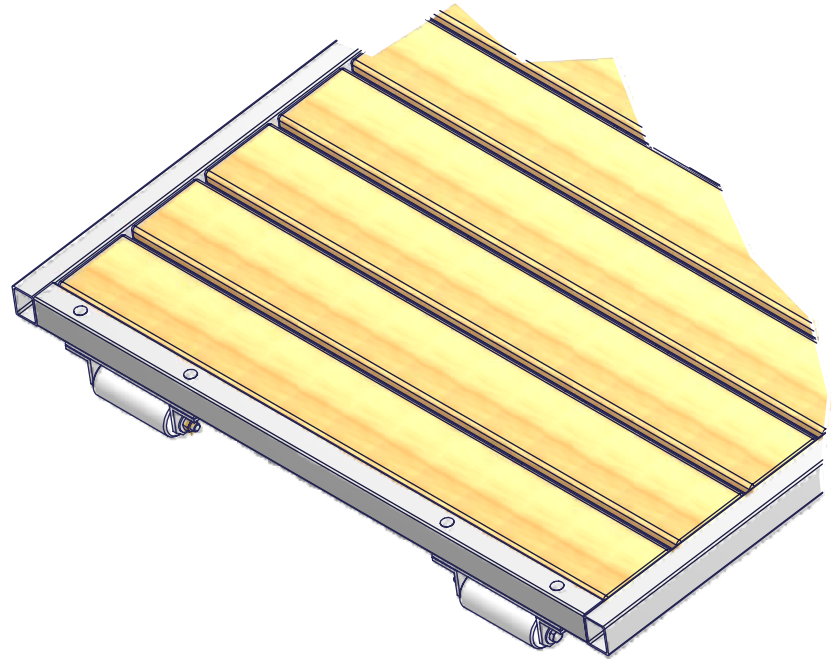

Bolt-On Ramp Roller Kit (Pair)			P/N: DARAMPRLK
ITEM	QTY	PART NUMBER	DESCRIPTION
1	2	NA	Ramp Sold Separately
2	2	APPD06PHR	6 IN UHMW ROLLER
3	4	S120WASHR	WASHER FLAT 1/2 SS
4	2	B12 LOCNUT	NUT 1/2 NYLOC BRASS
5	2	MS120800B	1/2 X 8 S.S. HEX BOLT
6	4	S380WASHR	WASHER FLAT 3/8 SS
7	4	B380RGNUT	NUT 3/8 - 16 BRASS
8	4	CS380312B	3/8" x 3.5" S.S. Carriage Bolt
9	2	230002170	Ramp Roller Bolt-On Kit Weldment